

## 5:1 Ratio Fire-Ball® Pumps

306518Y

900 psi (6.2 MPa, 62 bar) Maximum Working Pressure  
180 psi (1.2 Ma, 12 bar) Maximum Air Input Pressure

Models 203872  
203857  
204254  
222087

### Oil Pumps



**Read warnings and instructions.**  
See page 19 for model numbers.

### CAUTION

These pumps are designed to pump lubricating fluids only.

## Table of Contents

Warnings .....	2
Installation .....	5
Operation .....	8
Troubleshooting .....	10
Air Motor and Throat Service .....	11
Displacement Pump Service .....	15
Air Motor Parts List .....	16
Air Motor Parts Drawing .....	16
Pump Parts Drawing .....	17
Pump Parts List .....	17
Technical Data .....	18
Pump Models and Dimensional Drawings ...	19
Mounting Hole Layout .....	19
Graco Standard Warranty .....	20
Graco Phone Number .....	20

Model 203876

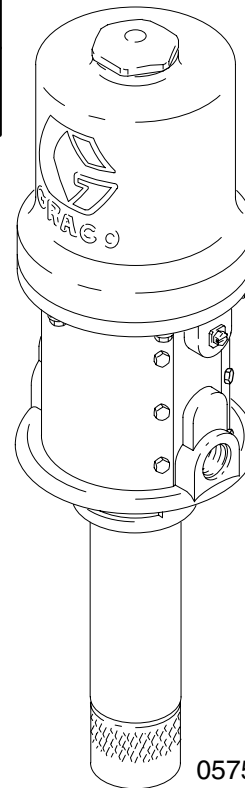

05750B

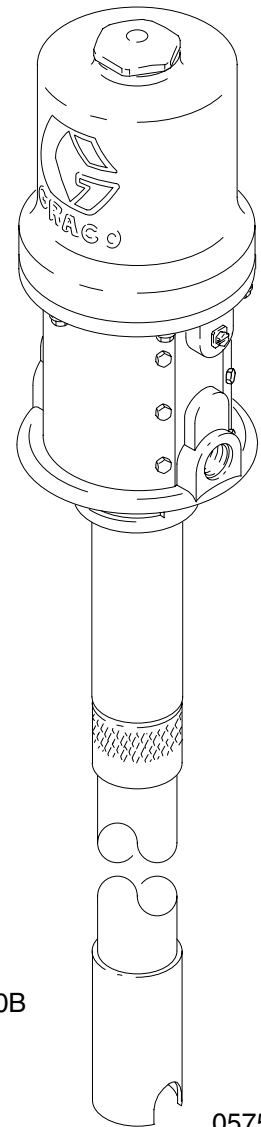

05751B

PROVEN QUALITY. LEADING TECHNOLOGY.

# Symbols

## Warning Symbol



This symbol alerts you to the possibility of serious injury or death if you do not follow the instructions.

## Caution Symbol



This symbol alerts you to the possibility of damage to or destruction of equipment if you do not follow the instructions.

## WARNING



### EQUIPMENT MISUSE HAZARD

Equipment misuse can cause the equipment to rupture or malfunction and result in serious injury.

- This equipment is for professional use only.
- Read all instruction manuals, tags, and labels before operating the equipment.
- Use the equipment only for its intended purpose. If you are not sure, call your Graco distributor.
- Do not alter or modify this equipment. Use only genuine Graco parts and accessories.
- Check equipment daily. Repair or replace worn or damaged parts immediately.
- Do not exceed the maximum working pressure of the lowest rated component in your system. This equipment has a **900 psi (6.2 MPa, 62 bar) maximum working pressure at 180 psi (1.2 MPa, 12 bar) maximum incoming air pressure.**
- Use fluids and solvents which are compatible with the equipment wetted parts. Refer to the **Technical Data** section of all equipment manuals. Read the fluid and solvent manufacturer's warnings.
- Do not use 1,1,1-trichloroethane, methylene chloride, other halogenated hydrocarbon solvents, or fluids containing such solvents in pressurized aluminum equipment. Such use could result in a chemical reaction, with the possibility of explosion.
- Handle hoses carefully. Do not pull on hoses to move equipment.
- Route hoses away from traffic areas, sharp edges, moving parts, and hot surfaces. Do not expose Graco hoses to temperatures above 82°C (180°F) or below -40°C (-40°F).
- Do not lift pressurized equipment.
- Comply with all applicable local, state, and national fire, electrical, and safety regulations.

# WARNING



## FLUID INJECTION HAZARD

Fluid from the dispensing valve, leaks, or ruptured components can inject fluid into your body and cause extremely serious injury, including the need for amputation. Fluid splashed in the eyes or on the skin can also cause serious injury.

- If a fluid injection injury occurs, get **emergency medical care at once**. **Do not treat as a simple cut**. Tell the doctor exactly what fluid was injected.
- Do not point the dispensing valve at anyone or at any part of the body.
- Do not put your hand or fingers over the end of the dispensing valve.
- Do not stop or deflect leaks with your hand, body, glove or rag.
- Use only extensions and no-drip tips which are designed for use with your dispensing valve.
- Do not use a low pressure flexible nozzle with this equipment.
- Follow the **Pressure Relief Procedure** on page 8 if the dispensing valve clogs before you clean, check or service the equipment.
- Tighten all fluid connections before operating the equipment.
- Check the hoses, tubes, and couplings daily. Replace worn or damaged parts immediately. Do not repair high pressure couplings; you must replace the entire hose.



## TOXIC FLUID HAZARD

Hazardous fluids or toxic fumes can cause serious injury or death if splashed in the eyes or on the skin, inhaled, or swallowed.

- Know the specific hazards of the fluid you are using.
- Store hazardous fluid in an approved container. Dispose of hazardous fluid according to all local, state and national guidelines.
- Always wear protective eyewear, gloves, clothing and respirator as recommended by the fluid and solvent manufacturer.

# WARNING



## FIRE AND EXPLOSION HAZARD

Improper grounding, poor ventilation, open flames or sparks can cause a hazardous condition and result in a fire or explosion and serious injury.

- Ground the equipment and the object being lubricated. See **Grounding** on page 7.
- If there is any static sparking or you feel an electric shock while using this equipment, **stop dispensing immediately**. Do not use the equipment until you identify and correct the problem.
- Provide fresh air ventilation to avoid the buildup of flammable fumes from solvents or the fluid being dispensed.
- Keep the dispensing area free of debris, including solvent, rags, and gasoline.
- Do not smoke in the dispensing area.



## MOVING PARTS HAZARD

Moving parts can pinch or amputate your fingers.

- Do not operate the pump with the air motor plates removed.
- Keep clear of all moving parts when starting or operating the pump.
- Before servicing the equipment, follow the **Pressure Relief Procedure** on page 8 to prevent the equipment from starting unexpectedly.

# Installation

The typical installation shown in Fig. 1 is only a guide for selecting and installing a pump; it is not an actual system design. Contact your Graco distributor for assistance in designing a system to suit your needs.

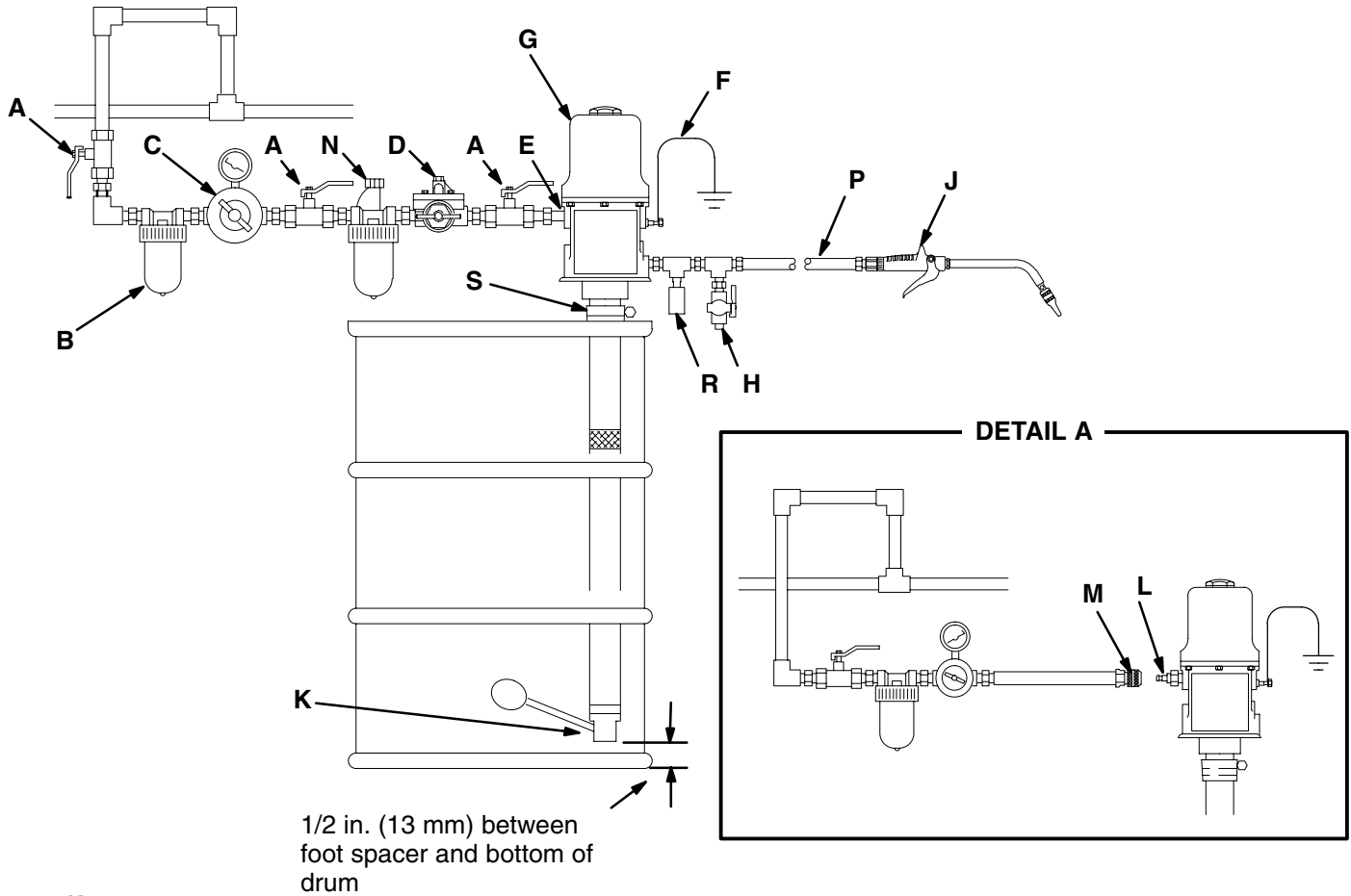

1/2 in. (13 mm) between foot spacer and bottom of drum

## Key

- |  |   |
|--|---|
| <p><b>A</b> Bleed-type master air valve (required if quick-disconnect fitting [L] and coupler [M] are not installed) <i>Order Part No. 107142.</i></p> <p><b>B</b> Air line filter</p> <p><b>C</b> Air regulator and gauge</p> <p><b>D</b> Pump runaway valve</p> <p><b>E</b> Air inlet</p> <p><b>F</b> Ground wire (required) <i>Order Part No. 222011.</i></p> <p><b>G</b> Pump (Model 204254 shown)</p> | <p><b>H</b> Drain valve (required) <i>Order Part No. 210658.</i></p> <p><b>J</b> Dispensing valve</p> <p><b>K</b> Low-level cut-off valve</p> <p><b>L</b> Male quick-disconnect fitting</p> <p><b>M</b> Female quick-disconnect coupler</p> <p><b>N</b> Air line lubricator</p> <p><b>P</b> Fluid hose</p> <p><b>R</b> Thermal relief kit (required) <i>Order Part No. 237893.</i></p> <p><b>S</b> Bung adapter <i>Models 204254 and 222087</i></p> |
|--|---|

Fig. 1

041  
15A

# Installation

1. Install the pump on the drum cover so that the pump's fluid intake is 1/2 in. (13 mm) off the bottom of the drum, as shown in Fig. 1.
2. *On Models 204254 and 222087*, screw the bung adapter tightly into the drum cover's bung hole, adjust the position of the pump in the drum, and tighten the bung adapter screw to hold the pump.

## ⚠ CAUTION

Always mount the pump firmly to a bracket or a tank cover. Never operate the pump while it is not mounted. Such use could damage the pump and fittings.

## System Accessories

## ⚠ CAUTION

Do not hang the air accessories directly on the air inlet (E). The fittings are not strong enough to support the accessories and may break. Provide a bracket on which to mount the accessories.

## ⚠ WARNING

Four accessories are **required** in your system: an air shut-off valve/air bleed device, fluid drain valve, thermal relief kit, and ground wire. These accessories help reduce the risk of serious bodily injury, including fluid injection, splashing in the eyes or on the skin, injury from moving parts if you are adjusting or repairing the pump, and explosion from static sparking.

- The air bleed device relieves air trapped between it and the air motor after the air supply is shut off. Trapped air can cause the air motor to cycle unexpectedly, causing serious injury if you are adjusting or repairing the pump. Use either a bleed-type master air valve (A) or a quick-disconnect coupler (M) and fitting (L). Install them near the pump air inlet within easy reach from the pump.
- The fluid drain valve (H) assists in relieving fluid pressure in the displacement pump, hoses, and dispensing valve. Triggering the valve to relieve pressure may not be sufficient.
- The thermal relief kit (R) assists in relieving pressure in the pump, hose, and dispensing valve due to heat expansion.
- The ground wire (F) reduces the risk of static sparking.

**NOTE:** Install these accessories in the order shown in Fig.1:

- Install a pump runaway valve (D) to shut off the air to the pump if the pump accelerates beyond the pre-adjusted setting. A pump that runs too fast can be seriously damaged.

## ⚠ CAUTION

Never allow the pump to run dry of the fluid being pumped. A dry pump will quickly accelerate to a high speed, possibly damaging itself, and it may get very hot.

- Install an air line lubricator (N) for automatic air motor lubrication.
- Install a bleed-type master air valve (A) to relieve air trapped between it and the motor when the valve is closed. *Order Part No. 107142.* As an alternative, you can install an air line quick disconnect coupler (M) and fitting (L) to serve as an air-bleed device. See Detail A in Fig.1.
- Install a Thermal Relief Kit (K) on the dispensing valve side of the pump. *To order a 900 psi (6.2 MPa, 62 bar) Thermal Relief Kit, order Part No. 237893.*
- Install the air regulator (C) to control pump speed and pressure.
- Install an air line filter (B) to remove harmful dirt and contaminants from your compressed air supply. Install another bleed-type master air valve (A) to isolate the accessories for servicing.
- Install a drain valve (H) near the pump fluid outlet. *Order Part No. 210658.*
- Install a suitable fluid hose (P) and dispensing valve (J).

# Installation

## Grounding

Proper grounding is an essential part of maintaining a safe system.

To reduce the risk of static sparking, ground the pump. Check your local electrical code for detailed grounding instructions for your area and type of equipment. Be sure to ground all of this equipment:

- *Pump:* Use a ground wire and clamp as shown in Fig. 2.
- *Air and Fluid hoses:* Use only electrically conductive hoses.
- *Air compressor:* Follow manufacturer's recommendations.
- *Fluid supply container:* Follow the local code.
- *To maintain grounding continuity when flushing or relieving pressure,* always hold a metal part of the valve firmly to the side of a grounded metal pail, then trigger the valve.

**To ground the pump,** remove the ground screw (Z) and insert through the eye of the ring terminal at end of ground wire (Y). Fasten the ground screw back onto the pump and tighten securely. Connect the other end of the ground wire to a true earth ground. See Fig. 2. *To order a ground wire and clamp, order Part No. 222011.*

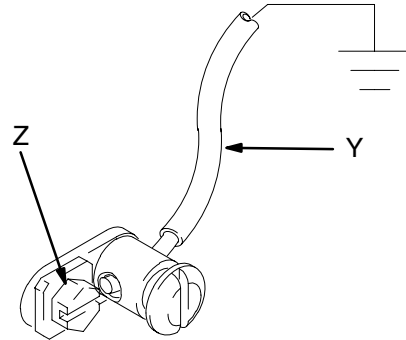

**Fig. 2**

T11052

# Operation

## Pressure Relief Procedure

### WARNING



#### PRESSURIZED FLUID HAZARD

The equipment stays pressurized until pressure is manually relieved. To reduce the risk of serious injury from pressurized fluid, accidental spray from the valve, or splashing fluid, follow this procedure whenever you

- Are instructed to relieve pressure
- Stop dispensing
- Check, clean, or service any system equipment
- Install or clean dispensing devices

1. Close the pump air regulator and the bleed-type master air valve (required in your system).
2. Hold a metal part of the dispensing valve firmly to a grounded metal waste container, and trigger the valve to relieve the fluid pressure.

### WARNING



#### COMPONENT RUPTURE HAZARD

The maximum working pressure of each component in the system may not be the same. To reduce the risk of overpressurizing any component in the system, be sure you know the maximum working pressure of each component. **Never** exceed the maximum working pressure of the lowest rated component in the system. Overpressurizing any component can result in rupture, fire, explosion, property damage, and serious injury.

To determine the fluid output pressure using the air regulator reading, multiply the ratio of the pump by the air pressure shown on the regulator gauge. For example:

5 (:1) ratio x 100 psi air = 500 psi fluid output

5 (:1) ratio x 0.7 MPa air = 3.5 MPa fluid output

5 (:1) ratio x 7 bar air = 35 bar fluid output

Limit the air pressure to the pump so that no air line or fluid line component or accessory is overpressurized.

## Starting and Adjusting the Pump

### WARNING



#### MOVING PARTS HAZARD

Never operate the pump with the warning plate (20) or the identification plate (18) removed. These plates protect your fingers from getting pinched or amputated by moving parts in the air motor.

### WARNING



#### HAZARDOUS VAPORS

The air motor exhaust coming out of the muffler could contain harmful materials, such as oil, antifreeze, or some of the material being pumped.

1. With the air regulator (C) closed, open the bleed-type master air valves (A), or, if so equipped, join the quick-disconnect coupler (M) to the male fitting (L).
2. Open the dispensing valve (J) into a grounded metal waste container, making firm metal-to-metal contact between the container and valve.
3. Open the pump air regulator (C) slowly, just until the pump is running. When the pump is primed and all air has been pushed out of the lines, close the dispensing valve.

**NOTE:** When the pump is primed, and with sufficient air supplied, the pump starts when the dispensing valve is opened and shuts off when it is closed.

4. Adjust the air regulator until you get sufficient flow from the dispensing valve. Always run the pump at the lowest pressure necessary to get the desired results. Do not exceed the maximum working pressure of any component in the system.

# Operation

5. If your pump accelerates quickly or is running too fast, stop it immediately and check the fluid supply. If the supply container is empty and air has been pumped into the lines, prime the pump and lines with fluid, or flush it and leave it filled with a compatible solvent. Be sure to eliminate all air from the fluid lines.
6. Read and follow the instructions supplied with each component in your system.
7. If the pump will be unattended for any period of time, if there is an air supply interruption, or at the end of the work shift, shut off the system and always **relieve the pressure**.

## CAUTION

Never allow the pump to run dry of the fluid being pumped. A dry pump will quickly accelerate to a high speed, possibly damaging itself, and it may get very hot.

## WARNING

To reduce the risk of serious injury whenever you are instructed to relieve pressure, always follow the **Pressure Relief Procedure** on page 8.

### NOTES:

- The low-level cut-off valve accessory (K) closes the pump fluid intake when the fluid level is low, which prevents air from entering the system.
- A pump runaway valve (D) should be installed on the air line to automatically shut off the pump if it starts to run too fast.

# Troubleshooting

**NOTE:** Check all other possible problems and solutions before disassembling the pump.

Problem	Cause	Solution
Pump fails to operate	Inadequate air supply pressure or restricted air lines	Increase air supply; clear
	Closed or clogged dispensing valve	Open; clear
	Clogged fluid lines, hoses, valves, etc.	Clear
	Damaged air motor	Service air motor
	Exhausted fluid supply	Refill and reprime or flush
Continuous air exhaust	Worn or damaged air motor gasket, packing, seal, etc.	Service air motor
Erratic pump operation	Exhausted fluid supply	Refill and reprime or flush
	Held open or worn intake valve or piston packings	Clear; service
Pump operates, but output low on up stroke	Held open or worn piston packings	Clear; service
Pump operates, but output low on down stroke	Held open or worn intake valve	Clear; service
Pump operates, but output low on both strokes	Inadequate air supply pressure or restricted air lines	Increase air supply; clear
	Closed or clogged valves	Open; clean
	Exhausted fluid supply	Refill and reprime or flush
	Clogged fluid lines, hoses, valves, etc.	Clear

Before you solve any troubleshooting problems, **relieve the pressure**, and disconnect the fluid line. If the pump starts when the air is turned on again, the line, dispensing valve, etc., is clogged.

## **WARNING**

To reduce the risk of serious injury whenever you are instructed to relieve pressure, always follow the **Pressure Relief Procedure** on page 8.

# Air Motor and Throat Service

## Before You Start

- Be sure you have all necessary parts on hand. **Pump Repair Kit 238286** includes repair parts for the pump and air motor. Use all the parts in the kit for the best results. Parts included in the kit are marked with one asterisk, for example (12\*), in the text and drawings. See the **Air Motor Parts List** on page 16 and the **Pump Parts List** on page 17.
- Two accessory tools should be used: **Padded Pliers, 207579**, are used to grip the trip rod without damaging its surface. **Gauge, 171818**, is used to ensure the proper clearance between the poppets and seat of the transfer valve.

## Disassembly

1. Flush the pump, and **relieve the pressure**.

### **⚠ WARNING**

To reduce the risk of serious injury whenever you are instructed to relieve pressure, always follow the **Pressure Relief Procedure** on page 8.

2. Disconnect the ground wire from the grounding screw (5b), disconnect the hoses, remove the pump from its mounting, and clamp the air motor base in a vise horizontally by closing the vice jaws on the flange.
3. Use a strap wrench on the fluid cylinder (105) to screw it out of the air motor base (5). See the **Parts Drawing** on page 17.
4. Pull the displacement rod (8) down as far as it will go. See Fig. 3.
5. Using wrenches on the flats of the displacement rod (8) and on the flats of the fluid piston (110), unscrew the fluid piston from the displacement rod. Remove the ball (111) from the end of the displacement rod, and remove the packing o-ring (104\*) from the fluid piston. See the **Parts Drawing** on page 17.
6. Clamp the air motor upright in the vise by closing the vice jaws below the flange.
7. Unscrew the cylinder cap nut (29) from the top of the air motor cylinder (17).
8. Pull up on the cylinder cap nut (29) to expose the trip rod, grasp the trip rod with padded pliers (*Part No. 207579*), and unscrew the cylinder cap nut from the trip rod.

### **⚠ CAUTION**

Do not damage the plated surface of the trip rod (11). Damaging the surface of the trip rod can result in erratic air motor operation. Use the special padded pliers to grasp the rod.

9. Remove the six screws (21) holding the air motor cylinder (17) to the air motor base (5), and carefully pull the cylinder straight up off of the piston (2).

### **⚠ CAUTION**

To avoid damaging the cylinder wall, lift the cylinder straight up off of the piston. Never tilt the cylinder while you are removing it.

10. Pull the air motor piston/displacement rod assembly (2, 8) clear of the air motor base (5) by pulling up on the air motor piston.
11. Remove the o-rings (9\*, 112\*) and u-cup packing (6\*) from the air motor base (5). Use needle-nose pliers to remove the u-cup packing from the bottom of the air motor base.

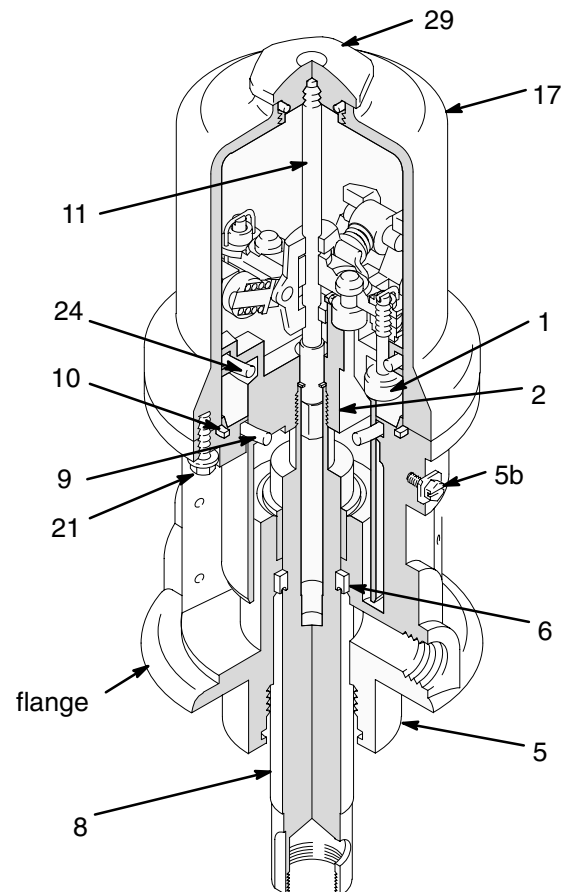

Fig. 3

05752B

# Air Motor and Throat Service

12. Remove the o-ring (24\*) from the air motor piston (2).
13. Clamp the displacement rod upright in the vice by closing the vice jaws on the flats of the displacement rod.
14. Use a screwdriver to push down on the trip rod yoke (22) to snap the toggles (M) down. See Fig. 4.
15. Remove the lockwires (31\*) from the adjusting nuts (30\*) of the transfer valves. Screw the top nuts off. Screw the valve poppet (1\*) stems out of the grommets (12\*) and bottom nuts (30\*). Take the valve poppets off of the stems, and squeeze them firmly to check for cracks.
16. Grip the toggle rockers (26) with pliers. Compress the springs (27) and swing the toggle assembly (M) up and away from the piston lugs (L), and remove the assembly. Check that the valve actuator (13) is supported by the spring clips (14), but slides easily into them. See Fig. 4.

## WARNING



### MOVING PARTS HAZARD

To reduce the risk of pinching or amputating your fingers, **always** keep fingers clear of the toggle assemblies (M).

17. Remove the trip rod yoke (22), actuator (13), and trip rod (11). Check the exhaust valve poppets (16\*) for cracks.

**NOTE:** To remove the exhaust valve poppets (16\*), stretch them out and cut them with a sharp knife.

## Cleaning and Servicing

1. Clean all the parts carefully in a compatible solvent and inspect for wear or damage. Use all the repair kit parts during reassembly, and replace other parts as necessary.
2. Check the polished surfaces of the air motor piston (2), displacement rod (8), and cylinder wall (17) for scratches or wear. A scored rod will cause premature packing wear and leaking.
3. Lubricate all parts with a light weight, water-resistant grease.

## Reassembly

1. Clamp the displacement rod (8) upright in the vice by closing the vice jaws on the flats of the displacement rod.
2. Pull the new exhaust valve poppets (16\*) into the valve actuator (13), and clip off the top parts of the poppets (shown with dotted lines in the **Cutaway View** in Fig. 4).
3. Install the new grommets (12\*) in the actuator (22), place the inlet valve poppets (1\*) in the piston, and thread the bottom valve nuts (30\*) onto the stems of the inlet valve poppets until there are a few threads left before the threads run out.  
**NOTE:** If you thread the valve nuts too far down onto the poppets, they will run off of the threaded part of the poppets.
4. Grease heavily and place the trip rod (11) in the air motor piston (2), place the actuator (13) in the yoke (22), and place the well-greased actuator/yoke assembly in the piston, with the trip rod going through the center holes of the actuator and yoke and the stems of the inlet valve poppets (1\*) going through the grommets (12\*).
5. Thread the top valve nuts (30\*) onto the stems of the inlet valve poppets (1\*) until one thread of the inlet valve poppets is exposed above the valve nuts.
6. Install the toggle pins (23) in the yoke (22), place the toggle arm (25) ends of the toggle assembly (M) onto the toggle pins, and snap the pivot pin (26) ends of the toggle assembly into the piston lugs (L).
7. Measuring with the gauge (*Part No. 171818*), create 0.145 in. (3.7 mm) of clearance between the inlet valve poppets (1\*) and the piston seat when the inlet valve is open. See the **Cutaway View** in Fig. 4.

**NOTE:** Adjust the distance between the inlet valve poppets and the piston seat by turning the top valve nuts (30\*).

8. Tighten the bottom valve nuts (30\*) by hand. The grommets (12\*) should be slightly compressed.
9. Align the holes in the valve nuts (30\*) and the slots on the stems of the inlet valve poppets (1\*), and drop the lock wires (31\*) through the holes in the valve nuts and into the slots in the stems of the inlet valve poppets. Pull the lock wires down tightly, and bend the ends with pliers so that they cannot be pulled back out of the holes.

# Air Motor and Throat Service

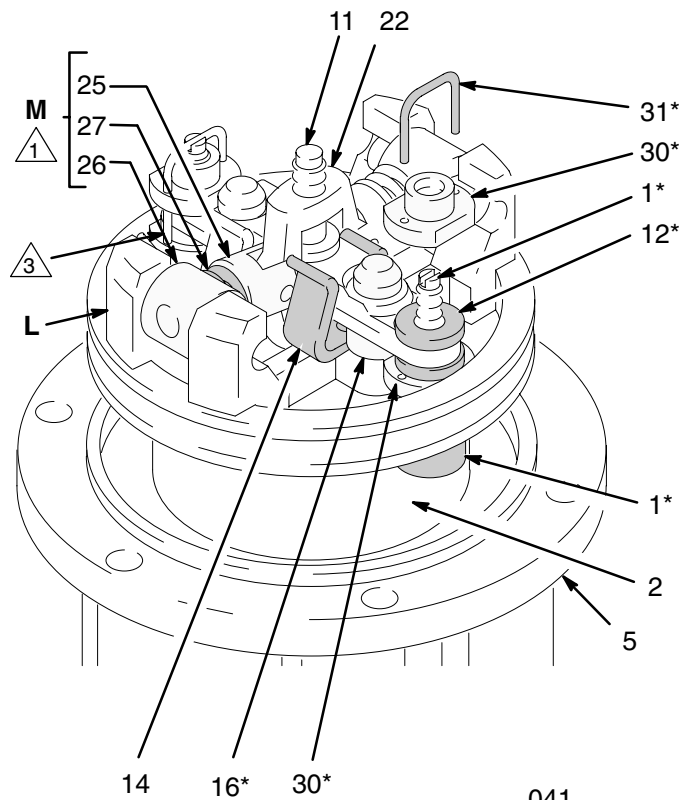

041  
19

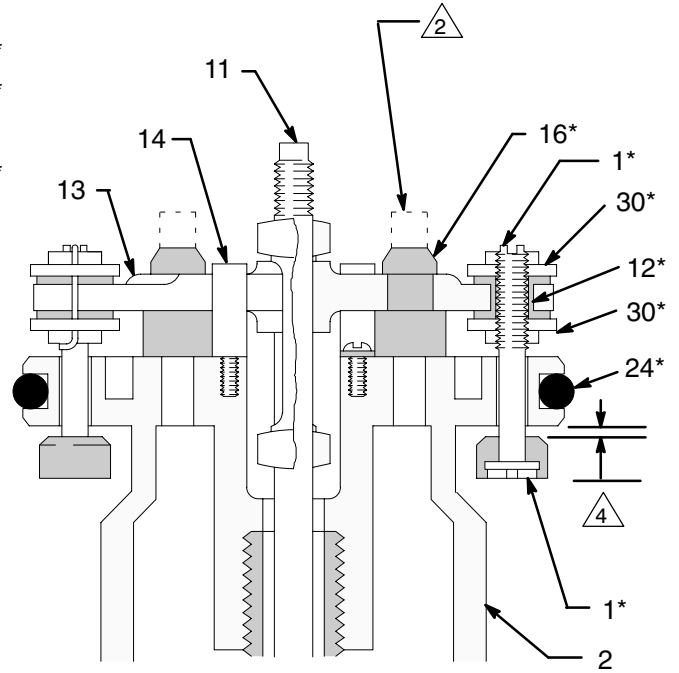

**Cutaway View**

041  
18

- △ 1 Push toggles (M) in and then up.
- △ 2 Cut off tops of poppets as indicated by dotted lines.
- △ 3 Turn wires up.
- △ 4 0.145 in. (3.7 mm) clearance between poppets (1\*) and seat when it is open.

**Fig. 4**

# Air Motor and Throat Service

## CAUTION

Never re-use the old lock wires. They will get brittle and break easily from too much bending.

10. Take the assembly out of the vice so that you can move it around for steps 11 and 12.
11. Grease and install the new o-rings (9\*, 24\*, 112\*).
12. Install the new u-cup packing (6\*) through the bottom of the air motor base, with the lips facing toward the bottom of the pump.
13. Slide the displacement rod (8) down through the packings, and lower the air motor piston (2) into the air motor base (5).
14. Clamp the air motor upright in the vice by closing the vice jaws below the flange.
15. Carefully lower the air motor cylinder (17) straight down onto the piston assembly (2). Tighten the six screws (21) holding the air motor cylinder to the air motor base (5).

## CAUTION

To avoid damaging the cylinder wall, lower the cylinder straight down onto the piston. Never tilt the cylinder as it is being lowered.

16. Pull the trip rod (11) so it is sticking up out of the air motor cylinder (17).

**NOTE:** You may have to hold the unit upside down to shake the trip rod loose.

17. Grip the trip rod (11) with padded pliers, screw the cylinder cap nut (29) onto the trip rod, push the cylinder cap nut down, and screw it into the top of the cylinder.

## CAUTION

Do not damage the plated surface of the trip rod (11). Damaging the surface of the trip rod can result in erratic air motor operation. Use the special padded pliers to grasp the rod.

18. Place the piston ball (109) in the displacement rod (8).
19. Clean the threads of the fluid piston (110), apply Loctite® to the threads, install the new packing o-ring (104\*) on the fluid piston, and thread the fluid piston onto the displacement rod (8).
20. Clamp the flats of the fluid piston (110) in a vice, and torque the displacement rod (8) to the piston to 40 to 60 ft-lb (54 to 81 N.m).
21. Clamp the air motor base (5) in a vise horizontally by closing the vice jaws on the flange.
22. Use a strap wrench to screw the displacement pump cylinder (105) to the air motor base (5), and torque to 95 to 105 ft-lb (129 to 142 N.m).
23. Before remounting the pump, connect an air hose and run the air motor slowly, starting with just enough air pressure to make the air motor run, and make sure that it operates smoothly.

## WARNING



### MOVING PARTS HAZARD

Never operate the pump with the warning plate (20) or the identification plate (18) removed. These plates protect your fingers from getting pinched or amputated by moving parts in the air motor.

24. Reconnect the ground wire before you resume regular pump operation.

# Displacement Pump Service

## Before You Start

Be sure you have all necessary parts on hand. **Pump Repair Kit 238286** includes repair parts for the pump and air motor. Use all the parts in the kit for the best results. Parts included in the kit are marked with one asterisk, for example (12\*), in the text and drawings. See the **Air Motor Parts List** on page 16 and the **Pump Parts List** on page 17.

1. Flush the pump, and **relieve the pressure**.

### **WARNING**

To reduce the risk of serious injury whenever you are instructed to relieve pressure, always follow the **Pressure Relief Procedure** on page 8.

2. Disconnect the hoses, remove the pump from its mounting, and clamp the air motor base in a vise horizontally by closing the vice jaws on the flange.
3. Unscrew the intake valve body (107) from the fluid cylinder (105). Disassemble the intake valve (see the **Parts Drawing**). Clean and inspect the parts for wear or damage, and replace parts as needed. Be sure to check the o-ring (108\*). Unless further intake valve service is needed, reassemble and reinstall, using liquid sealant on the male threads.
4. Use a strap wrench on the fluid cylinder (105) to screw it out of the air motor base (5). Carefully inspect the smooth inner surface of the cylinder for scoring or irregular surfaces. Such damage causes premature packing wear and leaking, so replace the part if it is damaged.
5. Using wrenches on the flats of the displacement rod (8) and on the flats of the fluid piston (110), unscrew the fluid piston from the displacement rod.
6. Take the ball (111) out of the displacement rod (8), and take the packing o-ring (104\*) off of the fluid piston (110).
7. Clean and inspect the parts. Use all the repair kit parts during reassembly, and replace other parts as necessary.
8. Place the piston ball (109) in the displacement rod (8).
9. Install the new packing o-ring (104\*) on the fluid piston (110).
10. Clamp the flats of the fluid piston (110) in a vice, and torque the displacement rod (8) to the piston to 40 to 60 ft-lb (54 to 81 N.m).
11. Clamp the air motor base (5) in a vise horizontally by closing the vice jaws on the flange.
12. Use a strap wrench to screw the displacement pump cylinder (105) to the air motor base (5), and torque to 95 to 105 ft-lb (129 to 142 N.m).
13. If you disconnected the ground wire, reconnect it before you resume regular pump operation.

# Air Motor Parts List

## All Models

Ref. No.	Part No.	Description	Qty.
1*	236079	POPPET, valve	2
2	160614	PISTON, air motor	1
5	238278	BASE, air motor (includes 5b-5c)	
5b	116343	.SCREW, grounding	1
5c▲	180233	.LABEL, warning	1
6*	112561	PACKING, u-cup	1
8	191124	ROD, displacement	1
9*	160625	O-RING; buna-N	1
10	160624	O-RING; buna-N	1
11	203965	ROD, trip	1
12*	158367	GROMMET; rubber	2
13	172867	ACTUATOR, valve	1
14	172866	CLIP, spring	2
15	102975	SCREW, rd hd mach; 6-32 x .25"	2
16*	170709	POPPET, valve	2
17	160613	CYLINDER, air motor	1
18	222499	PLATE, identification (with muffler)	1
19	100078	SCREW, hex washer hd mach; no. 8-32 x 0.38"	12
20	222501	PLATE, warning (with muffler)	1
21	101578	CAPSCREW, hex hd nylock; 5/16-18 x 0.88"	6
22	158360	YOKE, rod, trip	1
23	158362	PIN, toggle	2
24*	160621	O-RING; nitrile rubber	1
25	160623	ARM, toggle	2
26	158364	ROCKER, toggle	2
27	167585	SPRING, helical compression	2
28	156698	O-RING; buna-N	1
29	161435	NUT, cylinder cap	1
30*	160261	NUT, adjusting	4
31*	160618	LOCK WIRE, transfer valve	2
33	160932	GASKET; copper	1

\* Included in pump repair kit 238286

▲ Extra warning labels are available for free.



# Air Motor Parts Drawing

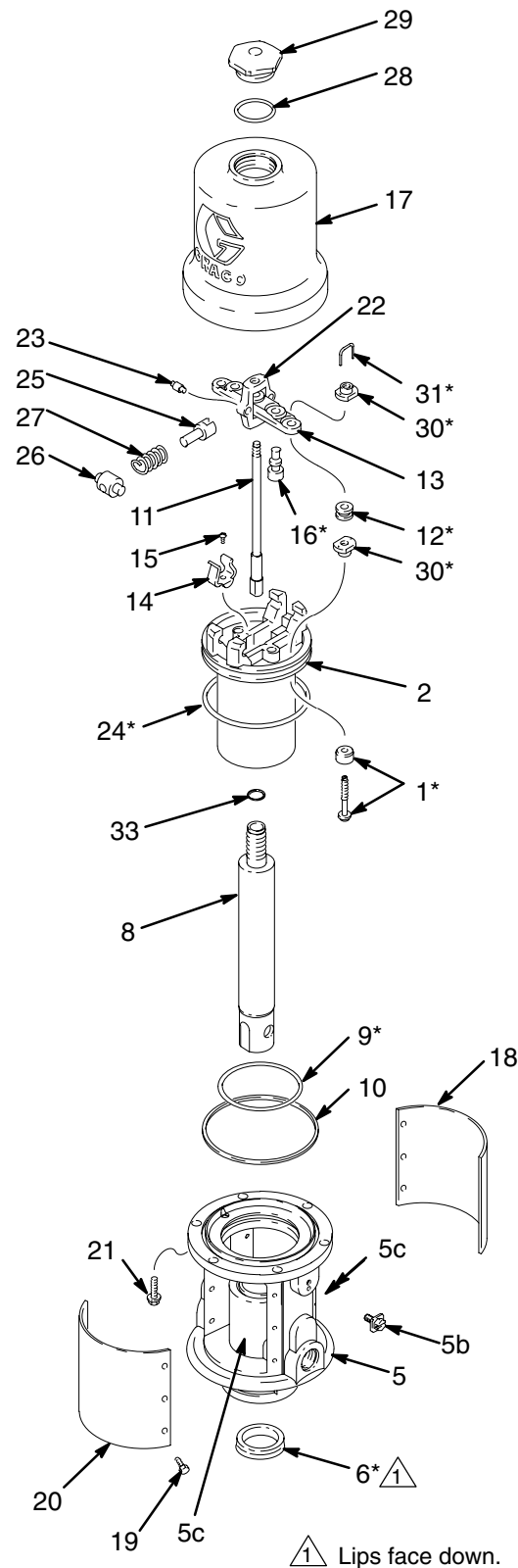

0588  
8B

# Pump Parts Drawing

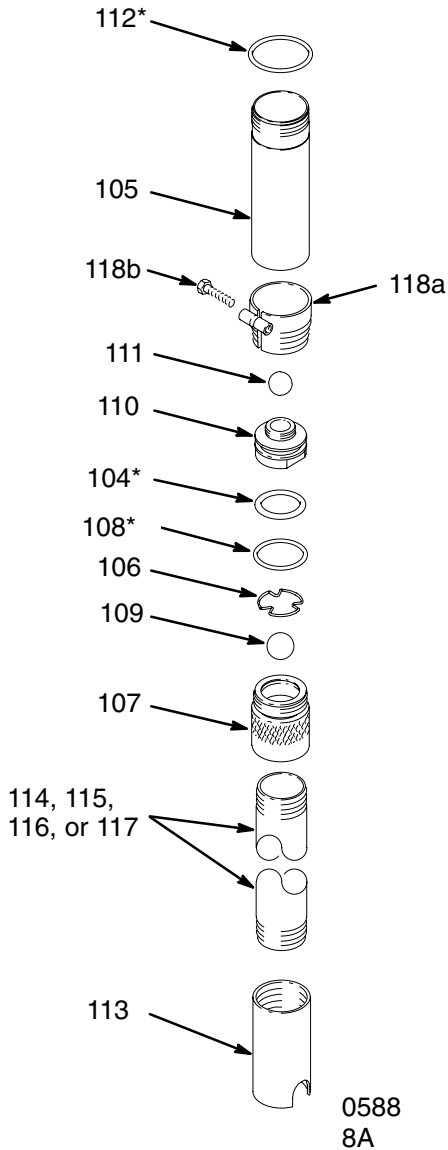

# Pump Parts List

**Model 203857, Series L 55 Gallon**  
*Includes items 101 to 114.*

**Model 203872, Series L 16 Gallon**  
*Includes items 101 to 113 and 115.*

**Model 203876, Series L Universal**  
*Includes items 101 to 112.*

**Model 204254, Series P  
55 Gallon Bung Mount**  
*Includes items 101 to 113, 116, and 118.*

**Model 222087, Series C  
275 Gallon Bung Mount**  
*Includes items 101 to 113, 117, and 118.*

Ref. No.	Part No.	Description	Qty.
101	238285	AIR MOTOR <i>Includes items 1 to 33 on page 16.</i>	1
104*	113423	PACKING, o-ring	1
105	191125	CYLINDER, fluid	1
106	157182	RETAINER, ball	1
107	183009	BODY, intake valve	1
108*	156633	O-RING, buna-N	1
109	101190	BALL, steel; 1" (25mm) dia.	1
110	191122	PISTON, fluid	1
111	100279	BALL, steel; 0.88" (22.2 mm) dia.	1
112*	156641	O-RING, buna-N	1
113	110127	SPACER, foot	1
114	191128	TUBE, extension; 21.75" (553 mm)	1
115	191126	TUBE, extension; 14.25" (362 mm)	1
116	191130	TUBE, extension; 26.0" (661 mm)	1
117	191131	TUBE, extension; 36.0" (915 mm)	1
118	222308	BUNG ADAPTER ASSEMBLY includes items 118a and 118b	
118a	104542	. SCREW, cap, hex hd; M8 x 1.25"	1
118b	210834	. ADAPTER, bung, bare	1

\* Included in pump repair kit 238286

# Pump Models and Dimensional Drawings

**Model 203876, Series L**  
Universal, wall mount

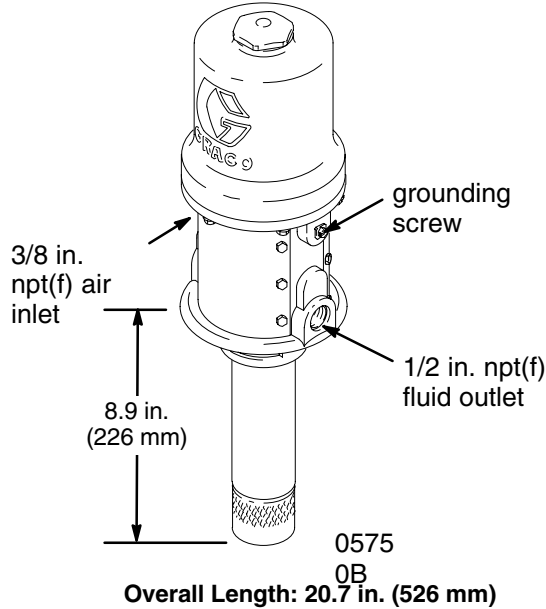

**Model 203857, Series L**  
55-gal. (400 lb) drum size, cover mount  
Overall Length: 45.6 in. (1158 mm)

**Model 203872, Series L**  
16-gal. (120 lb) drum size, cover mount  
Overall Length: 38.1 in. (968 mm)

**Model 204254, Series P**  
55-gal. (400 lb) drum size, bung mount  
Overall Length: 49.9 in. (1267 mm)  
*Bung adapter (118) is shown on page 17.*

**Model 222087, Series C**  
275-gal. tank size, bung mount  
Overall Length: 59.9 in. (1521 mm)  
*Bung adapter (118) is shown on page 17.*

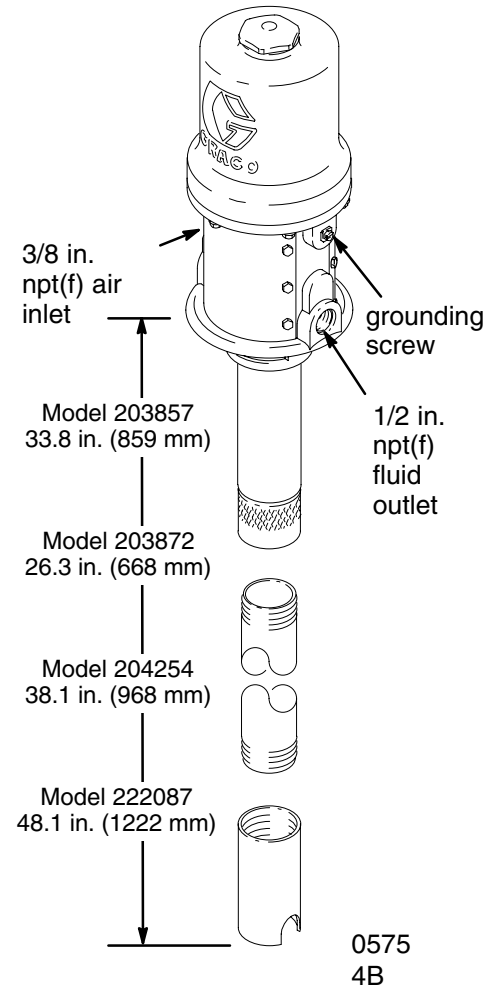

## Mounting Hole Layout

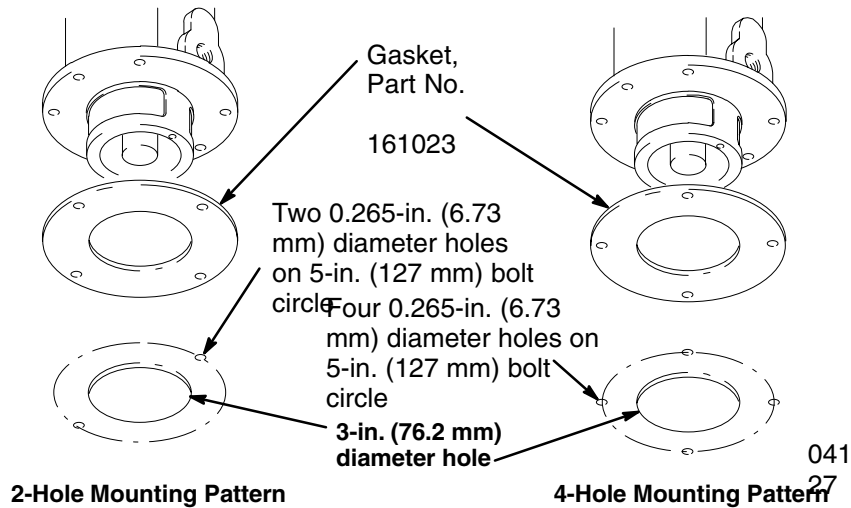

To order parts contact Florida Equipment Service

Tel: 800.488.5816

Fax: 904.378.9887

Email: [sales@flequipment.com](mailto:sales@flequipment.com)